

BOREHOLE DILATOMETER

Model DMP-95

GENERAL

Foundation studies in hard rock differ from the ones in soft soils by the fact that the bearing capacity is determined by the rock structure more than by its strength.

Rock mass is usually much weaker than the intact rock it contains. This is due to the presence of discontinuities such as joints, faults, shears and bedding planes.

Comprehensive in situ tests in mass rock must be performed on a large scale (2 to 3 m³ of material) in order to measure rock deformation and crack squeezing. These tests can be done with a DMP-95 dilatometer.

DESCRIPTION

Probe

The DMP-95 Dilatometer consists of a probe with an aluminium alloy central body. The probe includes:

- An inflatable membrane (rubber sleeve) equipped with three pairs of metallic inserts spaced at 120° intervals
- A split spring-ring and double cone membrane retaining system
- Three inductive displacement sensors
- A pressure sensor
- A sediment collector

The dilatometer probe is designed to be lowered down into the borehole using a string of rods. The sediment collector placed on top of the probe is equipped with a threaded end.

Standard connection: CRAELIUS 50 or 60

The probe is usually inflated with compressed dry gas (nitrogen or air).

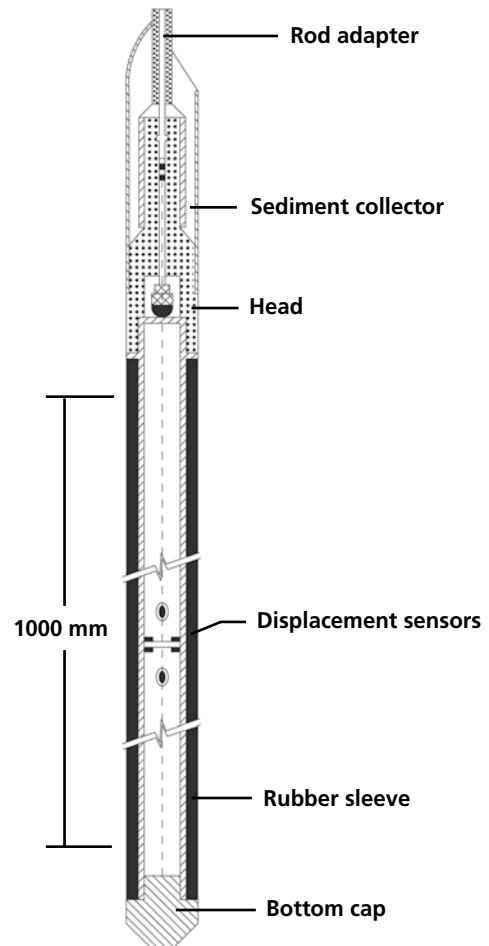

FEATURES

- Allows measurement of rock anisotropy
- May be used in deep boreholes
- Test in 101-mm size boreholes

Readout unit

The DMP-95 can be read using a DILAROC datalogger. This rugged portable unit allows for:

- Simultaneous reading of all DMP-95 built-in sensors (i.e. three displacement and one pressure sensor)
- ASCII data storage
- The use of a data acquisition system during creep phases
- Calibration data storage via RS-232 serial link

SPECIFICATIONS

PROBE	
Overall length	1.8 m (approx.)
Weight	45 kg (approx.)
O.D.	95 mm
Sleeve length	1000 mm
Total sensor opening pressure range	
101 mm	18 MPa
120 mm	2.5 MPa
DILAROC DATALOGGER	
Display	2×20 LCD with high-contrast digits
Direct programming	16-key keyboard
Storage capabilities	Approximately 2500 readings (each including 3 displacements and one pressure reading)

PERFORMANCES

DISPLACEMENT SENSORS	
Range	25 mm
Resolution (high resolution mode)	1 µm
Accuracy	±25 µm
PRESSURE SENSOR	
Standard range	20 000 kPa
Accuracy	0.1% F.S.
Display	10 kPa resolution
Maximum pressure use	18 000 kPa
Borehole diameter	101 mm (4 in.)

**Data analysis is done using calibration data previously stored in the DILAROC.*

Sensor accuracy is much greater than the DMP-95 probe, which is limited by the inflatable membrane, the contact between borehole walls, metallic inserts, etc.

0.1 to 0.2 mm diametrical deformation cycles are the lower limits of the dilatometer application range. In other words, the dilatometer is well suited for moduli between 5000 and 50 000 MPa.

ACCESSORIES

- High pressure, flexible, feeding tube (20 MPa in service)
- Reinforced electrical cables (up to 2 kN of load) are provided
- For lengths exceeding 100 m, special “extension” tubing and cable are recommended
- The DILAROC includes an RS-232 cable and a AC battery charger

OPTIONS

- 90 and 180 mm diameter dilatometers
- Electrical connector for GEVART OWEN 7 contact cables



PRODUCT RESELLER

Environmental Systems & Services | 8 River Street, Richmond VIC 3121 Australia |
T + 61 3 8420 8999 | F + 61 3 8420 8900 | geotechnical@esands.com | www.esands.com