

TRANSMISSION LINE VIBRATION RECORDER AND ANALYSER

Model PAVICA

APPLICATIONS

- Evaluates the in-situ vibration response of different line designs, tensions and hardware
- Estimates the nominal life expectancy of classical conductors subject to aeolian vibrations
- Rapidly identifies sites with potential line vibration problems
- Supports the proper selection and positioning of anti-vibration devices such as Stockbridge dampers and spacers-dampers
- Helps in drawing up realistic maintenance and refurbishment programs

DESCRIPTION

The PAVICA is a unique, small, lightweight instrument used to monitor and analyse vibrations in overhead transmission lines. The PAVICA measures the frequency and amplitude of all vibration cycles over all sampling periods, stores the data in a high-definition matrix and processes the results to provide a rough estimate of the life expectancy of conductors under study. These measurements and evaluation methods are based on the IEEE Standard on conductor vibration measurement and the CIGRE procedure for estimation of lifetime.

The PAVICA can be set directly onto the conductor in the vicinity of any type of clamp as opposed to other clamp-mounted commercial recorders, which are limited to metal-to-metal suspension clamps. The instrument consists of a gauged cantilever beam sensor, fastened to a clamp, which supports a short cylindrical housing. A feeler in contact with the conductor transmits motion to the sensor. The housing contains a microprocessor, an electronic circuitry, a power supply, a display and a temperature sensor.

This device combines the wide experience of Hydro-Québec's (IREQ) researchers in the field of conductor vibrations and the latest technology offered by RocTest Telemac engineers in the field of on-site measurements.



FEATURES

- Based on internationally accepted IEEE and CIGRE methods
- May be mounted directly on conductors (live or not) at suspension, spacer or damper clamps
- Ideal to use on lines fitted with cushioned attachment devices
- Comes with a specific software for fast and easy configuration and data retrieval
- Analyses collected vibration data in real time and provides built-in calculation of nominal conductor life expectancy
- High-resolution frequency and amplitude matrix (64 x 64) with user-programmable frequency and amplitude scales

INSTALLATION

The PAVICA may be installed on all types of conductors, under live or non-energized line conditions. The instrument is mounted directly onto the conductor. This greatly facilitates the installation and allows the instrument to be mounted not only at metal-to-metal suspension clamps, but also at cushioned supporting units and other damper and spacer attachment devices. Whenever the conductor's diameter is small, the recorder mass may interfere with the measurements. If such is the case, it may be required to use the split version of the recorder, whereby only the sensor is mounted onto the conductor, while the housing is mounted on a nearby fixed-line component.

OPERATION

For each cycle of vibration, the strain gauges generate an output signal proportional to conductor bending amplitude. The PAVICA measures the frequency and amplitude of each cycle of the signal and stores these data in the matrix, according to the number of occurrences. The matrix has 64 amplitude intervals by 64 frequency intervals, which makes 4096 counter cells, each cell having a capacity of 100 million events.

At the end of each monitoring period, the integrated microprocessor estimates the current nominal conductor life expectancy. This value is stored in memory and the microprocessor then returns to standby mode, awaiting the next start-up time. The PAVICA microprocessor can be accessed directly by any RS-232 communication link. Neither a separate readout unit nor complex programming is required to view the matrix content.

The PAVICA's menu-driven embedded software enables the user to quickly and easily enter all relevant parameters, as well as retrieve all stored data and results using a simple PC. It may be run under any version of Windows™ (95/98/2000, XP and NT). The software can also be used to update the PAVICA's internal flash ROM memory, which stores the PAVICA's operating program.

SPECIFICATIONS

Measuring principle	IEEE Bending Amplitude Standard
Evaluation method	Endurance limit method as per EPRI or estimation of lifetime as per CIGRE
Sensor type	Strain-gauged cantilever beam
Amplitude range	4 programmable scale patterns
Pattern	Peak-to-peak amplitude (in micrometers)
1	0–20, 20–41, 41–61, ... 1285 and over
2	0–14, 14–27, 27–41, ... 857 and over
3	0–7, 7–14, 14–20, ... 428 and over
4	0–3, 3–7, 7–10, ... 214 and over
Frequency range	2 programmable scale patterns
Pattern	Frequency (Hz)
1	0–1, 2–3, 4–5, 6–7, ... 126–127
2	0, 1, 2, 3, ... 63–127
Matrix size	4096 counters corresponding to 64 amplitude intervals and 64 frequency intervals
Matrix memory capacity	100 million counts per matrix cell
Active monitoring period	1 to 12 seconds (programmable)
Total period (active & standby)	1 to 60 minutes (programmable)
Operating temperature	–40 to +85°C
Autonomy	Up to 3 months
Battery	3 × 3.5V AA lithium type
Dimensions	18 × 13 × 7 cm (nominal)
Weight	Approx. 0.5 kg

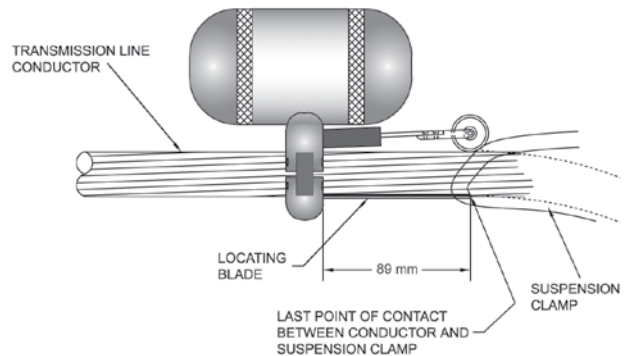

PAVICA Positioning in the Vicinity of a Suspension Clamp